

HH#:333S-9-250 KD SPRING

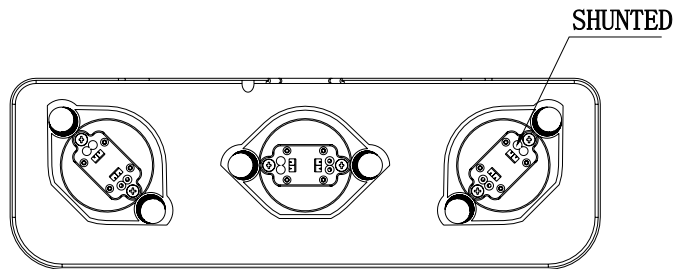
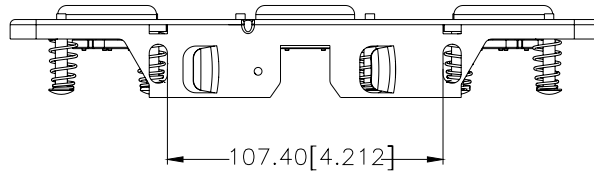
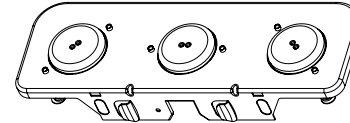
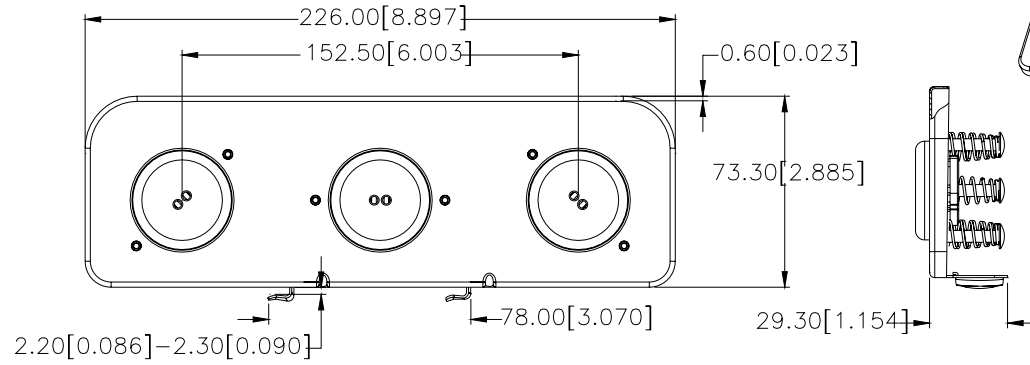

<b>H.H. FLUORESCENT PARTS.INC.</b>			UNLESS OTHERWISE SPECIFIED: DIMENSIONS ARE IN MM	
MODEL	SCALE 1??2	UNIT MM	DECIMALS TOLERANCES	ANGULAR
			.XX ±.05	± 0.5°
TITLE	MATERIAL	SHEET A4	.XXX ±.010	
		REV	DRAWN HYF	DATE 09.1.16
DRAW NO.	PAPER NO.		DESIGN	
			APPROVED	