

HH#:1-450W-2

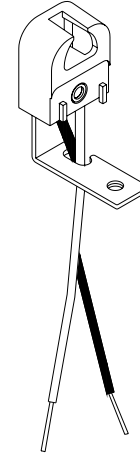
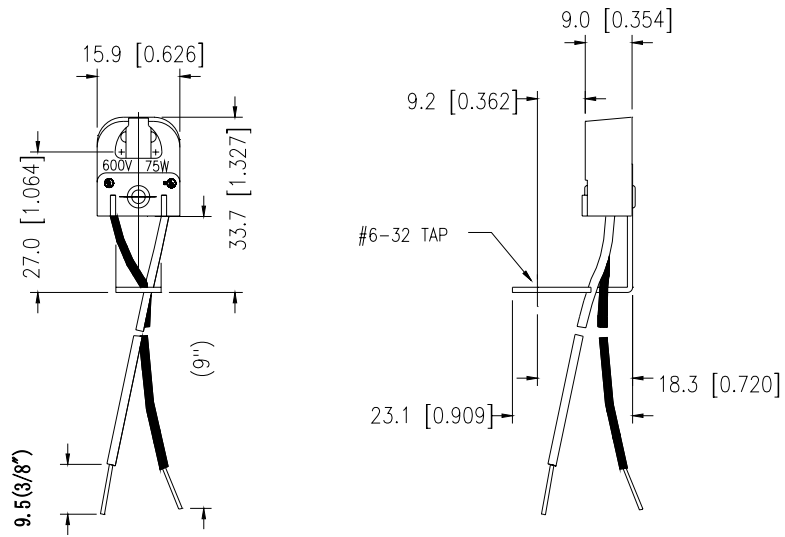

H.H. FLUORESCENT PARTS,INC.			UNLESS OTHERWISE SPECIFIED: DIMENSIONS ARE IN MM	
MODEL	SCALE 1??1	UNIT MM	DECIMALS TOLERANCES	ANGULAR
TITLE	MATERIAL	SHEET A4	.XX ±.05	± 0.5°
DRAW NO.	PAPER NO.	REV	DRAWN HYF	DATE 09.1.16
			DESIGN	
			APPROVED	